

PREFAMAX

Inloader for the transport of precast elements





FAYMONVILLE

TRAILERS TO THE **MAX**



With an **experience of over 50 years**, Faymonville is one of the biggest manufacturers of semi-trailers for special and heavy haulage.

Faymonville provides their customers with optimal solutions and systems for any transport need outside the usual norms.

Quality, flexibility, productivity, creativity and **service** are the company's keywords. The range of products and services is constantly enlarged in tight collaboration with our customers.



The **high level of innovation** and the excellent manufacturing quality of the products are secured by optimized production processes and own modern production plants in Büllingen (Belgium), Lentzweiler (Luxembourg) and Goleniow (Poland). A service station has been opened in Noginsk (near Moscow, Russia).





The Prefa**MAX** inloader is the ideal solution when it comes to transportation of concrete- components. The fully metalized Prefa**MAX** stands out thanks to high operational safety while offering optimal efficiency.

With a total width of 2.55m the Prefa**MAX** is within the norms for standard transports, whereby any additional costs for escorts and special authorizations can be avoided.

Main features

- Low tare weight
- More payload
- Optimized chassis with high stability
- Numerous included extras and additional useful options
- Well thought-out and user-oriented functionality down to the last detail
- Exclusive use of European quality components
- Complete in-house handling and production
- High operating safety
- Certified load securing system following VDI2700 for 30T payload
- Fast loading and offloading of the frames
- Easy handling
- RSS

The PREFAMAX-principle

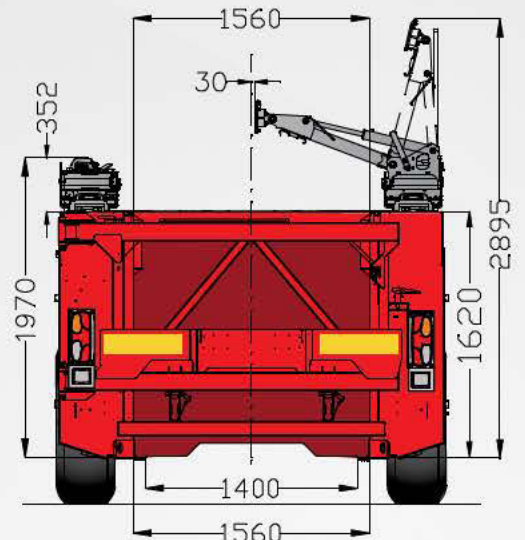
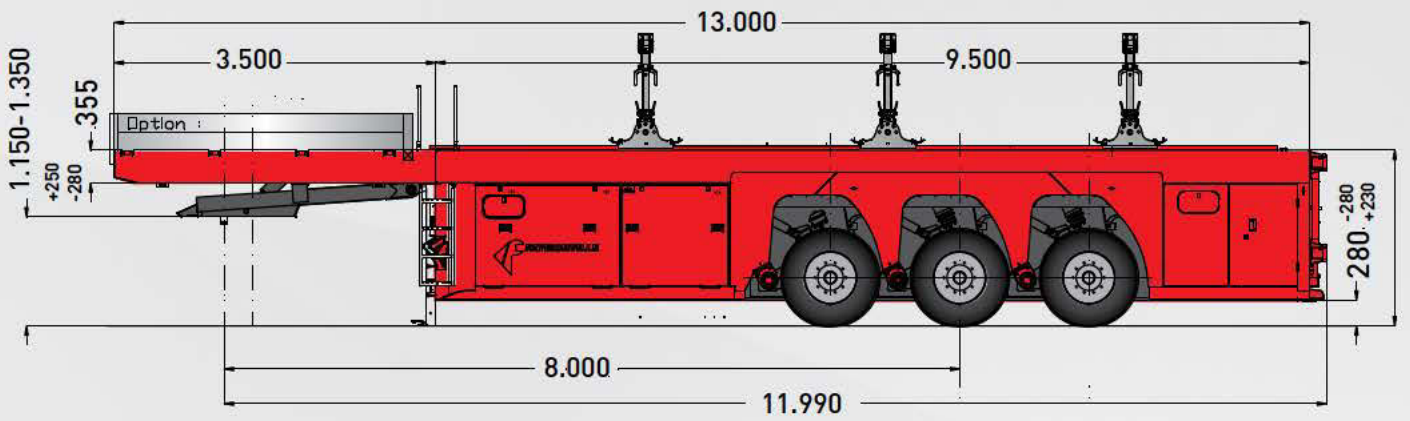
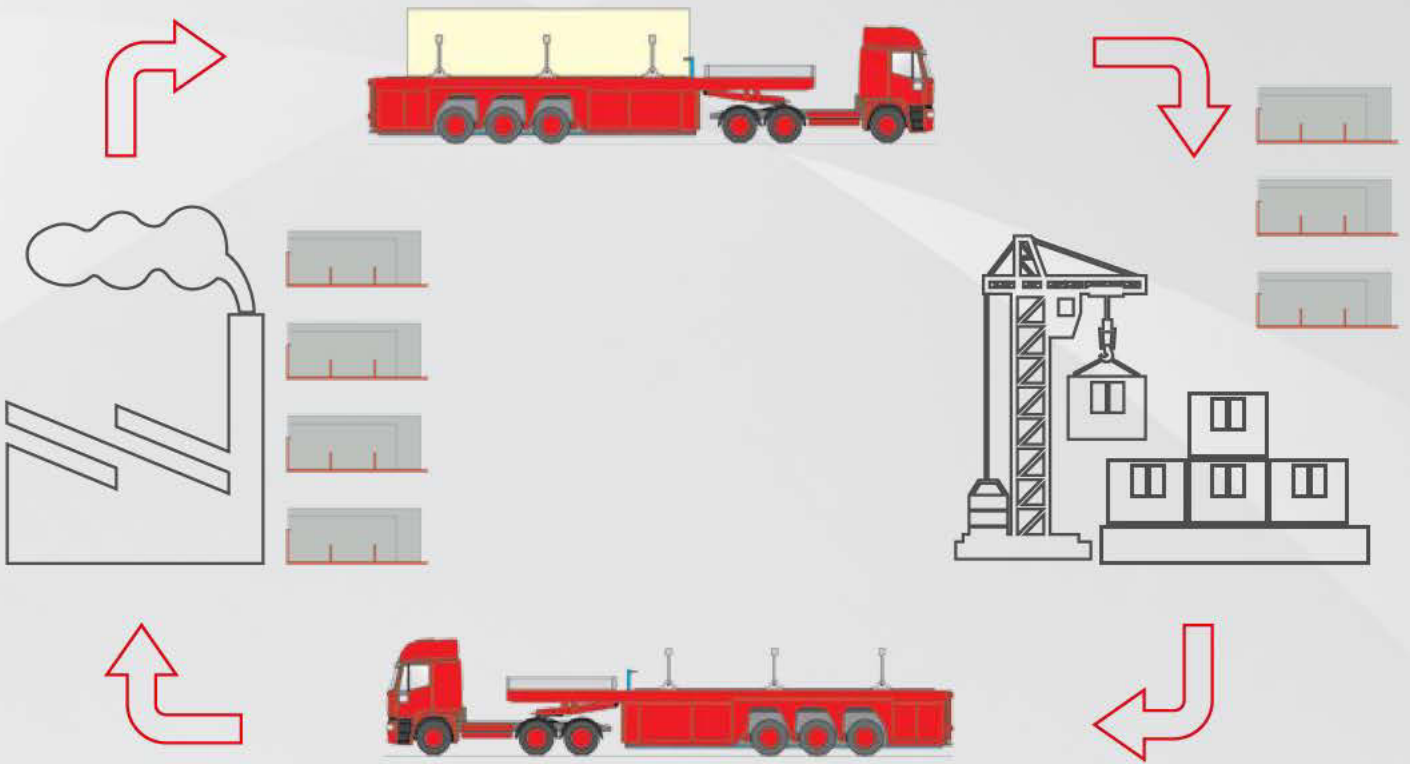

Faymonville is the only full-range transport system supplier for the precast concrete sector. Our wide range offers an adequate transport solution for all products within this market segment. Our motto: "configure to order".
*Define your need,
 we have the appropriate solution.*

PREFAMAX equipment

Principle - Loading / Unloading



Easy load securing

All operations can be performed safely from the ground!



Lateral anti fall guard on the I-beams



PREFAMAX equipment

1. Toolbox
2. Access ladder with railing

Options:

3. Billboard
4. Vertically swiveling rear door (hydraulically operated)
5. Hydraulic multi-purpose door, horizontally/vertically swiveling, adjustable in width
6. Crossbars for long material loading
7. Hydraulic pallet locking



The innovations at a glance

- **Safe:** Sliding and swiveling load securing system, easily operated from beneath. For 30.000kgs payload.
- **Standard:** 9 pairs of lashing rings (5.000kg each).
Standard lashing rings on the gooseneck
Standard storage area at the front of the gooseneck
Optional: Sideboards for the front part of the gooseneck
- **Fast & trouble-free:** Easy loading and offloading in confined spaces thanks to the optionally foldable rear door.
- **Practical:** Professionally and well-arranged storage boxes.
- **Stable axle suspension**
- **Solid welded bearing house**
- **Robust & long-lasting:** Continuous side beams with optimized stress repartition
- **Short total length:** 2 king pin positions; exchangeable by screwing for 2- and 3-axle truck
Standard ONLY with FAYMONVILLE.



PREFAMAX
LEICHTESTE seiner Klasse!
LEICHTEST in its class!

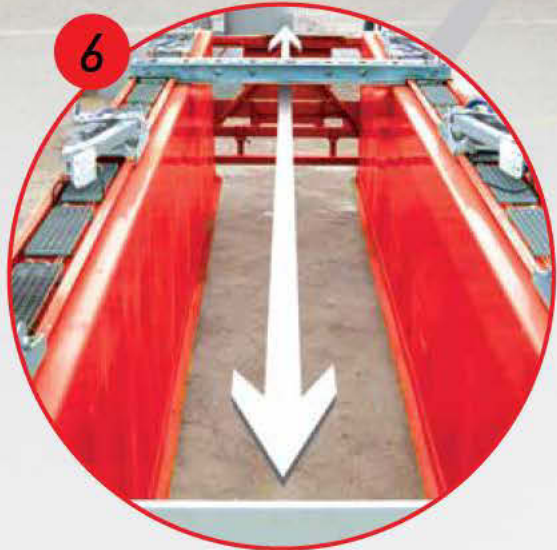

Vehicle types

Inloaders for the transport of precast concrete elements

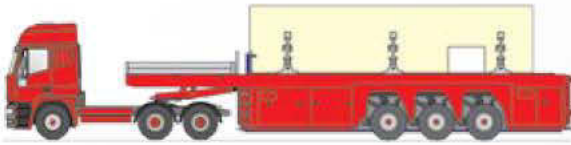

PREFAMAX Standard

± 9.800 Kg

- Clear loading length: 9.500 mm
- 3.500 mm long gooseneck, can be loaded
- Hydraulic suspension (optional: air suspension)
- 3/6-fold load securing
- Tires 385/65R22.5
- Complete lateral cover
- Rear swing clearance 2.000 + 2.300 mm

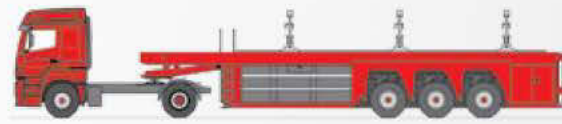

PREFAMAX Light

± 9.000 Kg

- Clear loading length: 9.800 mm
- 2.800 mm long gooseneck, can be loaded, with chamfered corners
- Air suspension
- 3/6-fold load securing
- Tires 385/65R22.5
- Lightweight collision guards
- Rear swing clearance 2.000 mm

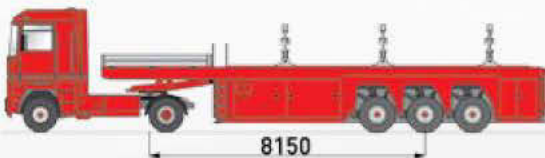

PREFAMAX Scandinavia N

± 10.200 Kg

- Clear loading length: 9.500 mm
- 3.500 mm long gooseneck, can be loaded
- Hydraulic suspension
- 3/6-fold load securing
- Tires 385/65R22.5
- Complete lateral cover
- Rear swing clearance 2.000 + 2.300 mm

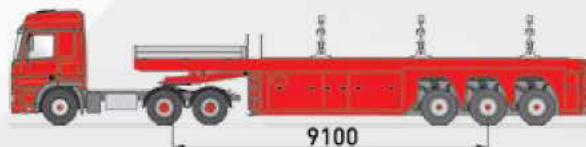

PREFAMAX Scandinavia S

± 10.200 Kg

- Clear loading length: 9.500 mm
- 3.500 mm long gooseneck, can be loaded
- Hydraulic suspension
- 3/6-fold load securing
- Tires 385/65R22.5
- Complete lateral cover
- Rear swing clearance 2.000 + 2.300 mm

Exclusive by FAYMONVILLE



PREFAMAX 10200

± 9.900 Kg

- Clear loading length: 10.200 mm
- 2.800 mm long gooseneck, can be loaded, with chamfered corners
- Hydraulic suspension
- 3/6-fold load securing
- Tires 385/65R22.5
- Complete lateral cover
- Lightweight collision guards
- Rear swing clearance 1.590 + 2.000 mm



PREFAMAX Extendable

± 12.000 Kg

- Clear loading length: 9.500 mm + 4.000 mm
- 3.500 mm long gooseneck, can be loaded
- Hydraulic suspension
- 3/6-fold load securing
- Tires 385/65R22.5
- Lightweight collision guards, GRP cover
- Rear swing clearance 2.000 + 2.300 mm



PREFAMAX City

± 7.700 Kg

- Clear loading length: 6.500 mm
- 2.800 mm long gooseneck, can be loaded, with chamfered corners
- Air suspension
- 2/4-fold load securing
- Tires 385/65R22.5
- Lightweight collision guards
- Rear swing clearance 2.000 mm



PREFAMAX City A

± 10.000 Kg

- Clear loading length: 7.100 mm + 2.400 mm
- 2.800 mm long gooseneck, can be loaded, with chamfered corners
- Hydraulic suspension
- 3/6-fold load securing
- Tires 385/65R22.5
- Lightweight collision guards, GRP cover
- Rear swing clearance 2.000 mm

The strengths of the extendable PREFAMAX at a glance:

Extendable

in different stages up to 4000 mm

Hydraulic pallet locking

for safe securing of the pallets

Safely located power supplies

Low empty weight

through intelligent design

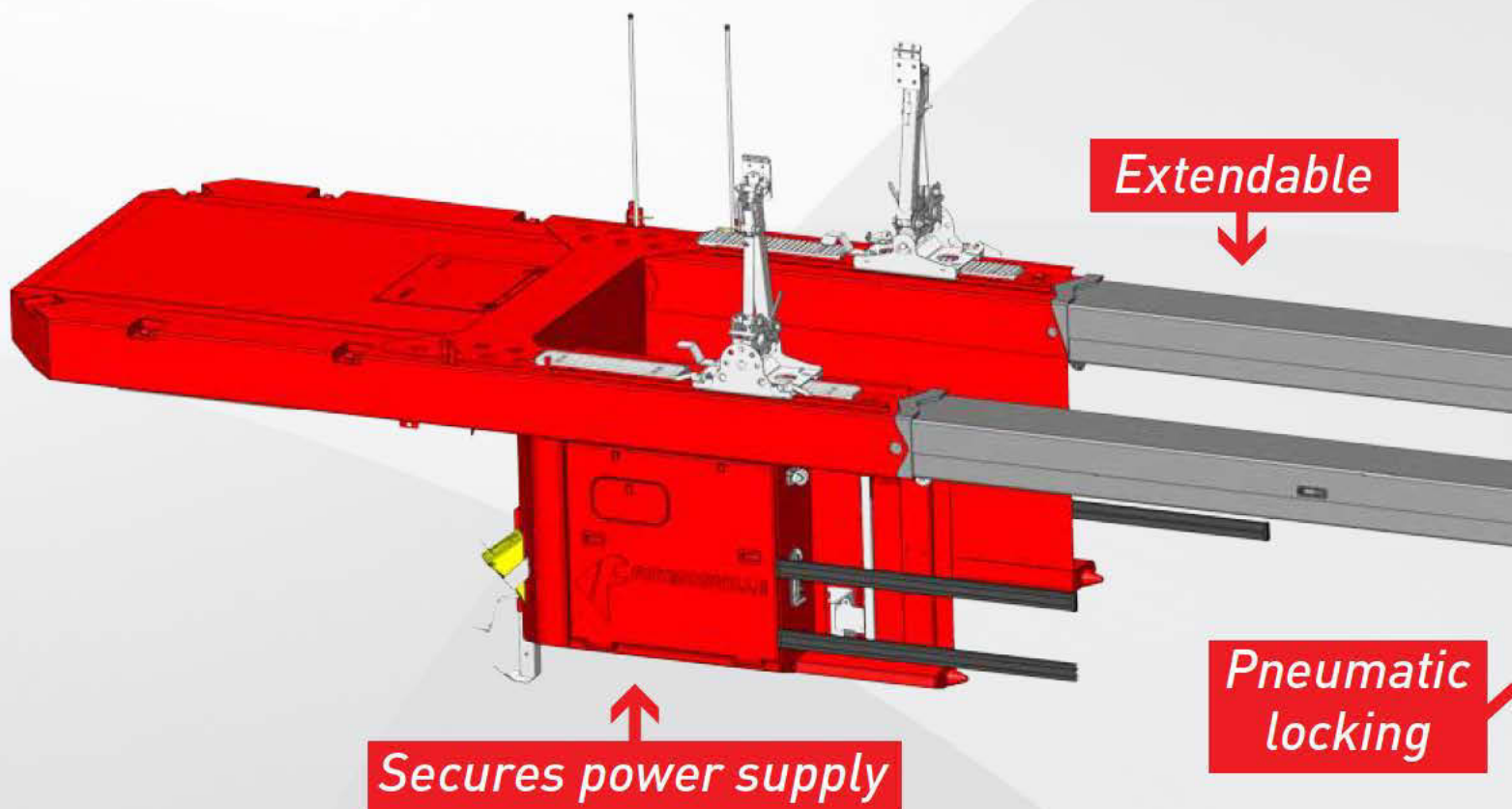

Multiply your possibilities



OVERLOADED



CORRECT LOAD



EXCLUSIVE
by **FAYMONVILLE**

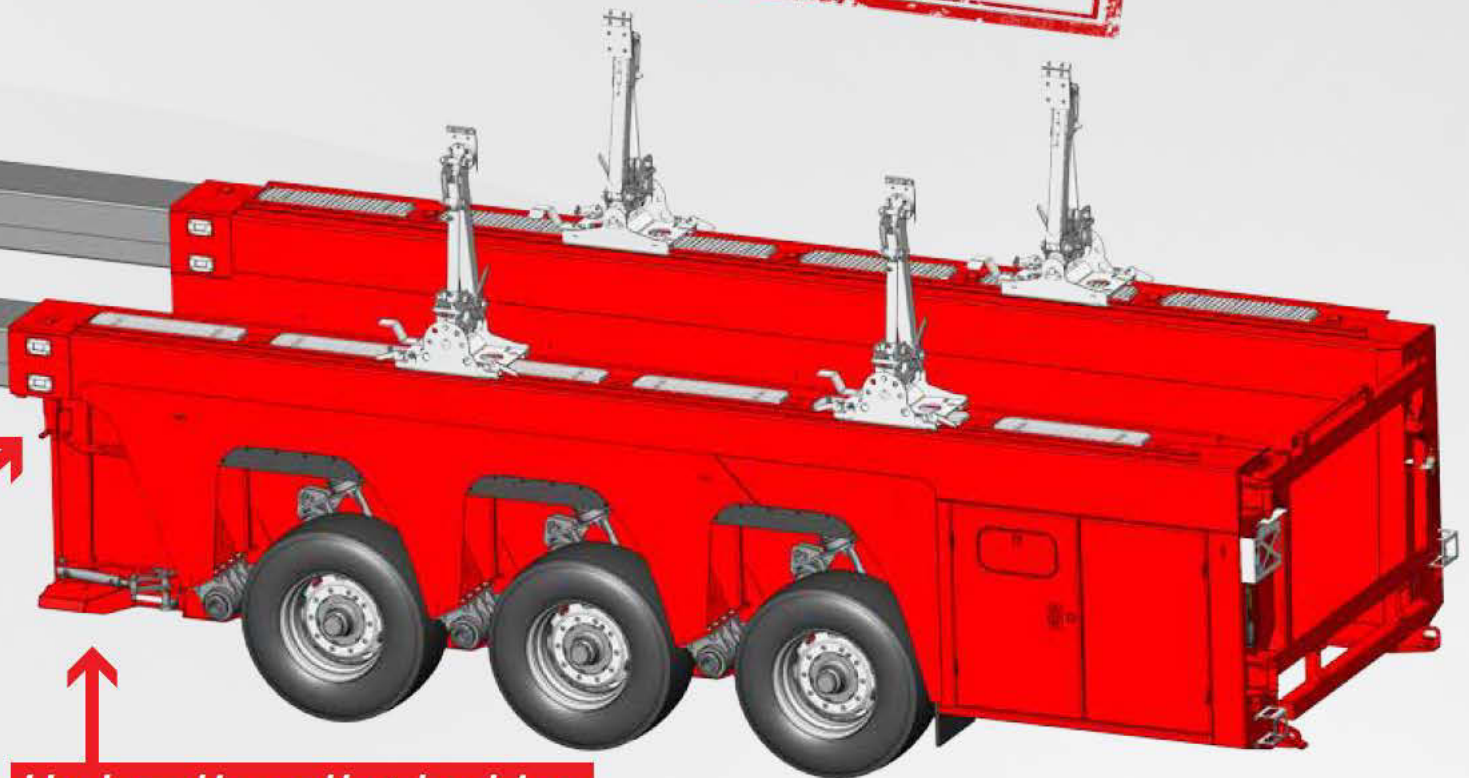

Hydraulic pallet locking

PREFAMAX in action



MAXPROTECT+

Weather conditions and environmental influences as well as corrosion and stone chips are the biggest enemies of a steel structure. For the long-term surface protection of semi-trailers, FAYMONVILLE relies on **MAXPROTECT+**, a fully co-ordinated and meticulously optimised surface treatment system.

MAXPROTECT+ is by far the best concept currently available in the industry. That is why it sets the benchmark in the field of surface protection. Our **MAXPROTECT+** treatment offers a long-life surface protection.

All stages and processes included in **MAXPROTECT+** – from the painting to the metallisation, including shot- and sandblasting – are carried out, developed and tested 'in-house'.

This optimum surface treatment additionally increases the quality and longevity of our products.

Composition of the surface refinement

- 1 Machine blasting**
Airless blast cleaning with metallic shot.
- 2 Manual blasting**
Manual cleaning and refinement of the material surface with mineral blasting agents.
- 3 Spray galvanising**
Application of a zinc/aluminium layer for corrosion and adhesion protection. Partial metallisation especially for strongly stressed surfaces.
- 4 Joint sealing**
Prevents the spread of rust in the gap and underneath the paintwork.
- 5 Priming**
2-component zinc epoxy with 81% zinc content and additional active corrosion protection.
- 6 Top coat**
Final coating with 2-component DTM.
- 7 Sealing**
Prevents corrosion in corners and hollow spaces.
- 8 Optional: Seawater-resistant complete preservation**

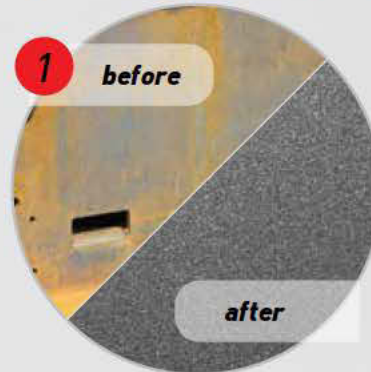



FAYMONVILLE DISTRIBUTION AG
8, Duarrefstrooss | L-9990 WEISWAMPACH
T: +352 / 26 90 04 155 | F: +352 / 26 90 04 425
sales@faymonville.com

www.faymonville.com

